



CSI: DIVISION: 03 00 00—CONCRETE
 Section: 03 16 00—Concrete Anchors

 DIVISION: 05 00 00—METALS
 Section: 05 05 19—Post-Installed Concrete Anchors

Product Certification System:

The ICC-ES product-certification system includes evaluating reports of tests of standard manufactured product, prepared by accredited testing laboratories and provided by the listee, to verify compliance with applicable codes and standards. The system also involves factory inspections, and assessment and surveillance of the listee’s quality system.

Product: Hilti Kwik Bolt TZ2 (KB-TZ2) Carbon and Stainless Steel Anchors in Cracked and Uncracked Concrete

Listee: HILTI, INC.

Compliance with the following standards:

- Annex D, Anchorage of CSA A23.3 (-14, -04), Design of Concrete Structures, CSA Group.

Compliance with the following codes:

Hilti Kwik Bolt TZ2 (KB-TZ2) Carbon and Stainless Steel Anchors in Cracked and Uncracked Concrete, as described in this listing report, are in conformance with CSA A23.3 (-14, 04), Annex D, as referenced in the applicable section of the following code editions:

- *National Building Code of Canada*® 2015 and 2010
 Applicable Section: Division B, Part 4, Section 4.3.3.

Description of anchors:

KB-TZ2 anchors are torque-controlled, mechanical expansion anchors. KB-TZ2 anchors consist of a stud (anchor body), wedge (expansion elements), nut, and washer. The anchor (carbon steel version) is illustrated in Figure 1. The stud is manufactured from carbon steel or AISI Type 304 or Type 316 stainless steel materials. Carbon steel KB-TZ2 anchors have a minimum 5 µm zinc-nickel plating. The expansion elements for the carbon steel KB-TZ2 anchors are fabricated from carbon steel. The expansion elements for the stainless steel KB-TZ2 anchors are fabricated from stainless steel. The hex nut for carbon steel conforms to ASTM A563-04, Grade A, and the hex nut for stainless steel conforms to ASTM F594-09.

The anchor body is comprised of a high-strength rod threaded at one end and a tapered mandrel at the other end. The tapered mandrel is enclosed by a three-section expansion element. The expansion element movement is restrained by the mandrel taper and by a collar. The anchor is installed in a predrilled hole with a hammer. When torque is applied to the nut of the installed anchor, the mandrel is drawn into the expansion element, which is in turn expanded against the wall of the drilled hole.

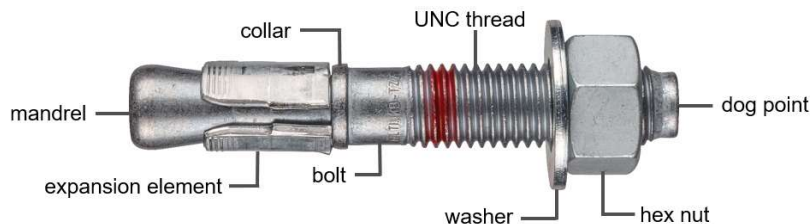

FIGURE 1—HILTI CARBON STEEL KWIK BOLT TZ2 (KB-TZ2)

Identification:

1. The anchors are identified by packaging labeled with the manufacturer's name (Hilti, Inc.) and contact information, anchor name, anchor size, and listing number (ELC-4266), and the ICC-ES listing mark. The anchors have the letters KB-TZ2 embossed on the on the anchor stud and a notch or notches embossed into the anchor head, and these are visible after installation for verification. Table 2 and Figure 4 summarize the length code identification system.
2. The report holder's contact information is the following:

HILTI, INC.
7250 DALLAS PARKWAY, SUITE 1000
PLANO, TEXAS 75024
(800) 879-8000
www.hilti.com

Installation:

Installation parameters are provided in Figures 2 and 3A and Table 1. Anchor locations must comply with this listing report and plans and specifications approved by the authority having jurisdiction. The Hilti KB-TZ2 must be installed in accordance with manufacturer's published instructions and this listing report. In case of conflict, this listing report governs. Anchors must be installed in holes drilled into the concrete using carbide-tipped masonry drill bits complying with ANSI B212.15-1994, using the Hilti SafeSet System™ with Hilti TE-YD or TE-CD Hollow Drill Bits complying with ANSI B212.15-1994 with a Hilti vacuum in accordance with Figure 3B, or using Hilti SPX-T core bits in accordance with Figure 3B. The Hollow Drill Bits are not permitted for use with the 1/4-inch and 3/8-inch diameter KB-TZ2 anchors. The Hilti SPX-T core bits are not permitted for use with the 1/4-inch and 1-inch diameter KB-TZ2 anchors. The minimum drilled hole depth, h_0 , is given in Table 1. If dust and debris is removed from the drilled hole with the Hilti TE-YD or TE-CD Hollow Drill Bits, the DRS attachment system, or compressed air or a manual pump, h_{nom} is achieved at the specified value of h_0 noted in Table 1. The anchor must be hammered into the predrilled hole until h_{nom} is achieved. The nut must be tightened against the washer until the torque values specified in Table 1 are achieved, or the anchors may be installed using the Hilti AT Tool in accordance with Figure 3B. The Hilti AT Tool is not permitted for use with the 1/4-inch, 3/4-inch and 1-inch diameter KB-TZ2 anchors.

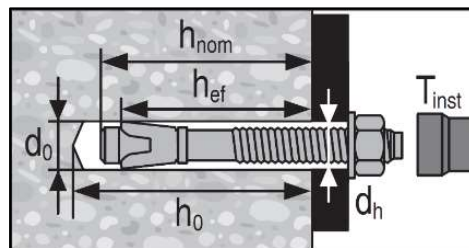
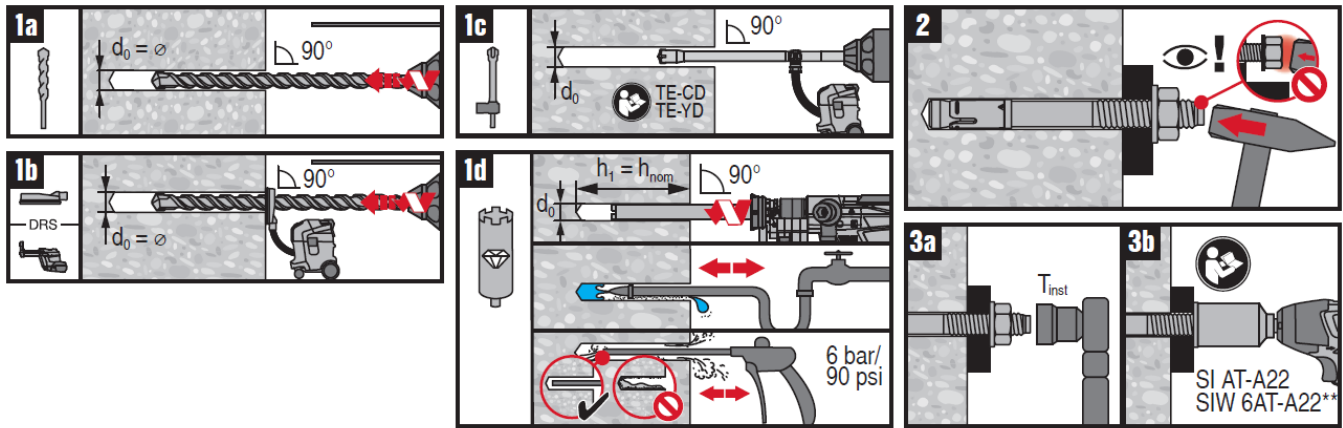

FIGURE 2—KB-TZ2 INSTALLED



Symbol	Setting Information	Units	Anchor Diameter [Inch]					
			1/4	3/8	1/2	5/8	3/4	1
	Hollow Drill Bit	-	-	-	✓	✓	✓	✓
	Dust Removal Systems	-	✓	✓	✓	✓	✓	✓
	Adaptive Torque System**	-	-	✓	✓	✓	-	-
	Diamond Core Bit	-	-	✓	✓	✓	✓	-

FIGURE 3A—INSTALLATION INSTRUCTIONS

Hilti SafeSet™ System with Hollow Drill Bit	Hilti Dust Removal Systems	Core Drill Systems
<p>Hilti TE-CD or TE-YD Hollow Carbide Drill Bit, with</p> <p>Hilti Vacuum</p>	<p>Hilti Rotary Hammer Drill with DRS (Dust Removal System) Module, or Hilti TE DRS-D Dust Removal System with Hilti Vacuum</p>	<p>Handheld Hilti DD 30 Core Drill, with SPX-T Hilti Core Bits</p>

FIGURE 3B—HILTI SYSTEM COMPONENTS

Ultimate Limit States Design:

Design resistance of anchors for compliance with the 2015 NBCC must be determined in accordance with CSA A23.3-14 Annex D and this listing report.

Design resistance of anchors for compliance with the 2010 NBCC must be determined in accordance with CSA A23.3-04 Annex D and this listing report.

Design parameters provided in Tables 4, 5, 6 and 7 of this listing report are based on the 2015 NBCC and 2010 NBCC (CSA A23.3-14 and CSA A23.3-04). The limit states design of anchors must comply with CSA A23.3-14 D.5.1 or CSA A23.3-04 D.5.1, as applicable, except as required in CSA A23.3-14 D.4.3.1 or CSA A23.3-04 D.4.3.1, as applicable.

Material resistance factors must be $\phi_c = 0.65$ and $\phi_s = 0.85$ in accordance with CSA A23.3 (-14, -04) Sections 8.4.2 and 8.4.3, and resistance modification factor, R , as given in CSA A23.3-14 Section D.5.3, or CSA A23.3-04 Section D.5.4, as applicable, and noted in Tables 4, 5, 6 and 7 of this listing report, must be used for load combinations calculated in accordance with Division B, Part 4, Section 4.1.3 of the 2015 NBCC, Division B, Part 4, Section 4.1.3 of the 2010 NBCC, or Annex C of CSA A23.3-14 or Annex C of CSA A23.3-04, as applicable. The factored steel strength N_{sar} or V_{sar} , in Tables 4, 5, 6 and 7 of this listing report have been multiplied by ϕ_s and R to determine the factored resistance. The factored pullout strengths $N_{cpr,uncr}$, $N_{cpr,cr}$ or $N_{cpr,eq}$ in Tables 4 and 5 of this listing report have been multiplied by ϕ_c and R to determine the factored resistance.

Requirements for Factored Pullout Resistance in Tension: The factored pullout resistance of a single anchor in accordance with CSA A23.3-14 D.6.3.1 and D.6.3.2, or CSA A23.3-04 D.6.3.1 and D.6.3.2, as applicable, in cracked and uncracked concrete, $N_{cpr,cr}$ and n_{cr} , $N_{cpr,uncr}$ and n_{uncr} , respectively, is given in Tables 4 and 5. For all design cases, $\Psi_{c,P} = 1.0$. In accordance with CSA A23.3-14 D.6.3, or CSA A23.3-04 D.6.3, as applicable, the factored pullout resistance in cracked concrete may be calculated in accordance with the following equation:

$$N_{cpr,cr,f'_c} = N_{p,cr} \left(\frac{f'_c}{17.2} \right)^{n_{cr}} \quad (\text{N, MPa}) \quad (\text{Eq-1})$$

In regions where analysis indicates no cracking in accordance with CSA A23.3-14 D.6.3.6, or CSA A23.3-04 D.6.3.6, as applicable, the factored pullout resistance in tension may be calculated in accordance with the following equation:

$$N_{cpr,uncr,f'_c} = N_{p,uncr} \left(\frac{f'_c}{17.2} \right)^{n_{uncr}} \quad (\text{N, MPa}) \quad (\text{Eq-2})$$

Where values for $N_{cpr,cr}$ or $N_{cpr,uncr}$ are not provided in Table 4 or Table 5, the pullout resistance in tension need not be evaluated.

Requirements for Critical Edge Distance: In applications where $c < c_{ac}$ and supplemental reinforcement to control splitting of the concrete is not present, the concrete breakout resistance in tension for uncracked concrete must be calculated in accordance with CSA A23.3-14 D.6.2 or CSA A23.3-04 D.6.2, as applicable.

In lieu of using CSA A23.3-14 D.9.7, or CSA A23.3-04 D.9.7, as applicable, values of c_{ac} must comply with Table 4 or Table 5.

TABLE 1—SETTING INFORMATION

Setting information	Sym.	Units	Nominal anchor diameter (in.)															
			1/4	3/8				1/2				5/8			3/4			1
Nominal Anchor O.D.	d_a	in. (mm)	0.250 (6.4)	0.375 (9.5)				0.500 (12.7)				0.625 (15.9)			0.750 (19.1)			1.00 (25.4)
Nominal bit diameter	d_o	in.	1/4	3/8				1/2				5/8			3/4			1
Effective min. embedment	h_{ef}	mm	38	38	51	64	38 ¹	51	64	83	70	83	102	83	95	121	102	146
Nominal embedment	h_{nom}	mm	44	48	64	76	51	64	76	95	83	95	114	102	114	140	117	162
Min. hole depth	h_o	mm	51	51	70	83	57	70	83	108	95	108	121	108	121	146	127	171
Installation torque Carbon steel ¹	T_{inst}	Nm	5	41				68				54			149			251
Installation torque Stainless steel ¹	T_{inst}	Nm	8	41				54				81			169			251
Fixture hole diameter	d_h	mm	7.9	11.1				14.3				17.5			20.6			28.6

¹ Design information for $h_{ef} = 38$ is only applicable to carbon steel (CS) KB-TZ2 bolts.

TABLE 2—LENGTH IDENTIFICATION SYSTEM (CARBON STEEL AND STAINLESS STEEL ANCHORS)¹

Length ID marking on bolt head		A	B	C	D	E	F	G	H	I	J	K	L	M	N	O	P	Q	R	S	T	U	V	W
Length of anchor, l_{anch} (mm)	From	38	51	64	76	89	102	114	127	140	152	165	178	191	203	216	229	241	254	279	305	330	356	381
	Up to but not including	51	64	76	89	102	114	127	140	152	165	178	191	203	216	229	241	254	279	305	330	356	381	406

¹ 3/8 diameter anchors with length of 89 are identified with an ohm (Ω) ID marking on the bolt head.

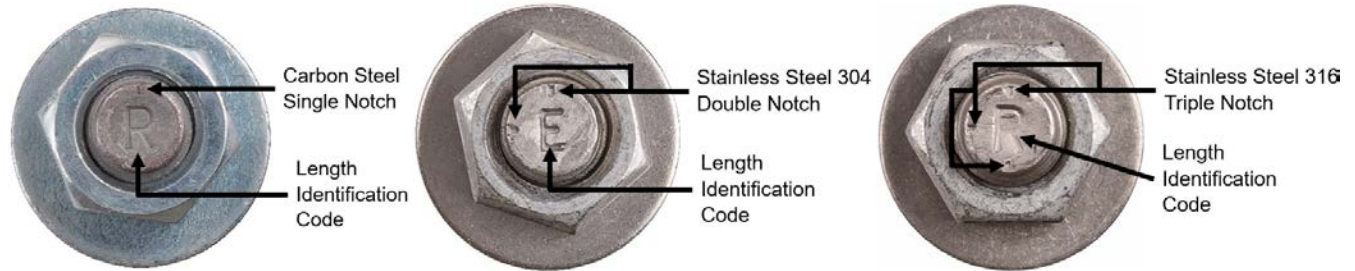

FIGURE 4—BOLT HEAD WITH LENGTH IDENTIFICATION CODE AND KB-TZ2 HEAD NOTCH EMBOSMENT

TABLE 3—MINIMUM EDGE DISTANCE, SPACING AND CONCRETE THICKNESS FOR KB-TZ2

Setting information	Symbol	Units	Nominal anchor dia. (in.)															
			1/4	3/8				1/2				5/8			3/4			1
Nominal Anchor O.D.	d_a	in. (mm)	0.250 (6.4)	0.375 (9.5)				0.500 (12.7)				0.625 (15.9)			0.750 (19.1)			1.00 (25.4)
Effective min. embedment	h_{ef}	mm	38	38	51	64	38	51	64	83	70	83	102	83	95	121	102	146
Min. member thickness	h_{min}	mm	83	83	102	127	89	102	127	140	127	140	152	140	152	203	203	254
Carbon Steel																		
Min. edge distance	c_{min}	mm	38	127	64	64	203	70	70	57	114	89	70	127	102	89	203	76
	for $s \geq$	mm	38	203	152	127	305	140	248	133	165	140	184	254	146	140	203	171
Min. anchor spacing	s_{min}	mm	38	127	57	51	305	89	76	51	114	70	57	114	95	95	203	121
	for $c \geq$	mm	38	203	89	102	203	254	203	121	140	178	108	152	191	121	203	95
Stainless Steel																		
Min. edge distance	c_{min}	mm	38	127	64	64		70	64	57	102	83	57	127	102	95	95	76
	for $s \geq$	mm	38	203	127	127		140	114	133	178	140	178	279	191	146	254	171
Min. anchor spacing	s_{min}	mm	38	127	57	57		70	64	51	140	70	76	127	102	102	127	121
	for $c \geq$	mm	38	203	102	89		105	127	121	140	102	108	203	152	133	108	95

TABLE 4—HILTI CARBON STEEL KB-TZ2 DESIGN INFORMATION FOR HAMMER AND CORE DRILLED INSTALLATIONS, TENSION¹⁰

Design parameter	Symbol	Units	Nominal anchor diameter (in)																				
			1/4		3/8		1/2			5/8			3/4			1							
Effective min. embedment ¹	h_{ef}	mm	38	38	51	64	38	51	64	83	70	83	102	83	95	121	102	146					
Tension, steel failure modes																							
Steel embed, material resistance factor for reinforcement	ϕ_s	-	0.85																				
Resistance modification factor for tension, steel failure modes ²	R	-	0.80																				
Min. specified yield strength	f_y	N/mm ²	696		696		664			600			584			517							
Min. specified ult. strength	f_{uta}	N/mm ²	844		870		786			736			730			607							
Effective tensile stress area	$A_{se,N}$	mm ²	15.4		33.2		63.6			106.0			154.4			303.2							
Steel strength in tension	N_s	kN	13.0		28.9		50.0			78.0			112.7			184.1							
Tension, concrete failure modes																							
Anchor category ³	-	-	3		1		1			1			1			1							
Concrete material resistance factor	ϕ_c	-	0.65																				
Resistance modification factor for tension, concrete failure modes, Condition B ⁶	R	-	0.75		1.0		1.0			1.0			1.0			1.0							
Effectiveness factor for uncracked concrete	k_{uncr}	-	10.0		10.0		11.3		10.0		10.0			11.3		11.3 ⁹		10.0		11.3		10.0	
Effectiveness factor for cracked concrete ⁴	k_{cr}	-	7.1		8.8		7.1		10.0		8.8		7.1		8.8		7.1		8.8			8.8	
Modification factor for anchor resistance, tension, uncracked concrete ⁵	$\psi_{c,N}$	-	1.0		1.0		1.0			1.0			1.0			1.0			1.0				
Critical edge distance	c_{ac}	mm	102	127	111	140	203	140	171	254	254	292	222	305	254	229	279	406					
Pullout strength uncracked conc. ⁷	$N_{p,uncr}$	kN	9.3	N/A	N/A	18.6	N/A	N/A	N/A	N/A	23.9	N/A	40.0	N/A	N/A	N/A	N/A	N/A					
Pullout strength cracked conc. ⁷	$N_{p,cr}$	kN	2.8	N/A	N/A	N/A	N/A	N/A	N/A	N/A	N/A	N/A	N/A	N/A	N/A	N/A	39.3	N/A	52.6				
Pullout strength Seismic ⁷	$N_{p,eq}$	kN	2.8	N/A	N/A	N/A	N/A	N/A	N/A	N/A	N/A	N/A	N/A	N/A	N/A	N/A	38.7	N/A	52.6				
Normalization factor, uncracked concrete	n_{uncr}	-	0.20	0.22	0.24	0.35	0.50	0.42	0.29	0.35	0.50	0.48	0.50	0.35	0.31	0.39	N/A	N/A					
Normalization factor, cracked concrete, seismic	n_{cr}	-	0.39	0.50	0.46	0.28	0.47	0.50	0.48	0.40	0.50	0.47	0.50	0.36	0.42	0.29	N/A	0.50					
Tension, axial stiffness																							
Axial stiffness in service load range ⁸	β_{uncr}	kN/mm	56.5		23.0		27.8			50.8			72.2			35.0							
	β_{cr}	kN/mm	5.4		16.0		19.9			29.3			10.9			21.4							

¹See Figure 2.

²The KB-TZ2 is a ductile steel element as defined by CSA A23.3-14 D.2 or CSA A23.3-04 D.2, as applicable.

³See CSA A23.3-14 D.5.3 or CSA A23.3-04 D.5.4, as applicable.

⁴See CSA A23.3-14 D.6.2.2 or CSA A23.3-04 D.6.2.2, as applicable.

⁵For all design cases $\psi_{c,N}=1.0$. The appropriate effectiveness factor for cracked concrete (k_{cr}) or uncracked concrete (k_{uncr}) must be used.

⁶For use with the load combinations of Division B, Part 4, Section 4.1.3 of the 2015 NBCC or 2010 NBCC, CSA A23.3-14 Annex C or CSA A23.3-04 Annex C, as applicable. Condition B applies where supplementary reinforcement in conformance with CSA A23.3-14 D.5.3(c) or CSA A23.3-04 D.5.4(c), as applicable, is not provided, or where pullout or pryout strength governs. For cases where the presence of supplementary reinforcement can be verified, the strength reduction factors associated with Condition A may be used.

⁷For all design cases $\psi_{c,p}=1.0$. NA (not applicable) denotes that this value does not control for design.

⁸Mean values shown, actual stiffness may vary considerably depending on concrete strength, loading and geometry of application.

⁹For core drill installations, $k_{uncr} = 10$ for 3/4-inch diameter anchors installed at 95 mm effective embedment.

¹⁰1/4-inch and 1-inch diameter anchors are not permitted for core drilling installations.

TABLE 5—HILTI STAINLESS STEEL KB-TZ2 DESIGN INFORMATION FOR HAMMER AND CORE DRILLED INSTALLATIONS, TENSION¹

Design parameter	Symbol	Units	Nominal anchor diameter (in)														
			1/4			3/8			1/2			5/8			3/4		
Effective min. embedment ¹	h_{ef}	mm	38	38	51	64	51	64	83	70	83	102	83	95	121	102	146
Tension, steel failure modes																	
Steel embed, material resistance factor for reinforcement	ϕ_s	-	0.85														
Resistance modification factor for tension, steel failure modes ²	R	-	0.80														
Min. specified yield strength	f_y	N/mm ²	696	664			664			632			580			448	
Min. specified ult. strength	f_{uta}	N/mm ²	844	828			830			790			693			689	
Effective tensile stress area	$A_{se,N}$	mm ²	15.4	33.2			63.6			106.0			154.4			303.2	
Steel strength in tension	N_s	kN	13.0	27.5			52.8			83.8			107.0			208.9	
Tension, concrete failure modes																	
Anchor category ³	-	-	3	1			1			1			1			1	
Concrete material resistance factor	ϕ_c	-	0.65														
Resistance modification factor for tension, concrete failure modes, Condition B ⁶	R	-	0.75	1.0			1.0			1.0			1.0			1.0	
Effectiveness factor for uncracked concrete	k_{uncr}	-	10.0	10.0			10.0			10.0			10.0	11.3 ⁹	10.0	11.3	
Effectiveness factor for cracked concrete ⁴	k_{cr}	-	7.1	8.8	7.1	7.1	8.8	7.1	8.8	7.1	8.8	7.1	8.8	8.8 ⁹	8.8	10.0	8.8
Modification factor for anchor resistance, tension, uncracked concrete ⁵	$\psi_{c,N}$	-	1.0	1.0			1.0			1.0			1.0			1.0	
Critical edge distance	c_{ac}	mm	102	114	140	105	140	159	191	254	165	222	305	254	254	279	394
Pullout strength uncracked concrete ⁷	$N_{p,uncr}$	kN	7.0	N/A	N/A	18.6	15.0	17.8	24.5	18.2	26.8	35.8	N/A	N/A	N/A	N/A	N/A
Pullout strength cracked concrete ⁷	$N_{p,cr}$	kN	3.0	N/A	N/A	N/A	N/A	N/A	N/A ¹⁰	N/A	N/A	N/A	N/A	N/A	39.1	N/A	N/A
Pullout strength seismic ⁷	$N_{p,eq}$	kN	3.0	N/A	N/A	N/A	N/A	N/A	N/A ¹⁰	N/A	N/A	N/A	N/A	N/A	39.1	N/A	N/A
Normalization factor, uncracked concrete	n_{uncr}	-	0.39	N/A	N/A	0.37	0.46	0.50	0.50	0.50	0.42	0.47	N/A	N/A	0.30	N/A	N/A
Normalization factor, cracked concrete, seismic	n_{cr}	-	0.50	N/A	N/A	N/A	N/A	N/A	0.50	N/A	N/A	N/A	N/A	N/A	0.50	N/A	N/A
Tension, axial stiffness																	
Axial stiffness in service load range ⁸	kN/mm	lb/in.	29.2	30.8			24.0			27.0			60.0			18.6	
	kN/mm	lb/in.	5.9	14.0			17.2			12.2			13.3			20.6	

¹See Figure 2.

²The KB-TZ2 is a ductile steel element as defined by CSA A23.3-14 D.2 or CSA A23.3-04 D.2, as applicable.

³See CSA A23.3-14 D.5.3 or CSA A23.3-04 D.5.4, as applicable.

⁴See CSA A23.3-14 D.6.2.2 or CSA A23.3-04 D.6.2.2, as applicable.

⁵For all design cases $\psi_{c,N} = 1.0$. The appropriate effectiveness factor for cracked concrete (k_{cr}) or uncracked concrete (k_{uncr}) must be used.

⁶For use with the load combinations of Division B, Part 4, Section 4.1.3 of the 2015 NBCC or 2010 NBCC, CSA A23.3-14 Annex C or CSA A23.3-04 Annex C, as applicable. Condition B applies where supplementary reinforcement in conformance with CSA A23.3-14 D.5.3(c) or CSA A23.3-04 D.5.4(c), as applicable, is not provided, or where pullout or pryout strength governs. For cases where the presence of supplementary reinforcement can be verified, the strength reduction factors associated with Condition A may be used.

⁷For all design cases $\psi_{c,p} = 1.0$. NA (not applicable) denotes that this value does not control for design.

⁸Mean values shown, actual stiffness may vary considerably depending on concrete strength, loading and geometry of application.

⁹For core drill installations, $k_{uncr} = 10$ and $k_{cr} = 7.1$ for 3/4-inch diameter anchors installed at 95 mm effective embedment.

¹⁰For core drill installations, $N_{p,cr} = 18.9$ kN and $N_{p,eq} = 18.9$ kN for 1/2-inch diameter anchors installed at 95 mm effective embedment.

¹¹1/4-inch and 1-inch diameter anchors are not permitted for core drilling installations.

TABLE 6—HILTI CARBON STEEL KB-TZ2 DESIGN INFORMATION FOR HAMMER AND CORE DRILLED INSTALLATIONS, SHEAR⁴

Design parameter	Symbol	Units	Nominal anchor diameter (in)															
			1/4		3/8			1/2			5/8		3/4			1		
Anchor O.D.	d_a	mm	6.4		9.5			12.7			15.9		19.1			25.4		
Effective min. embedment ¹	h_{ef}	mm	38	38	51	64	38	51	64	83	70	83	102	83	95	121	102	146
Shear, steel failure modes																		
Steel embed, material resistance factor for reinforcement	ϕ_s	-	0.85															
Resistance modification factor for shear, steel failure modes ²	R	-	0.75															
Steel strength in shear	V_s	kN	6.0	14.4	15.1	24.6	30.6	45.6	61.4	83.6	101.6							
Steel strength in shear, seismic	$V_{s,eq}$	kN	6.0	14.4	15.1	24.6	30.6	45.6	61.4	83.6	101.6							
Shear, concrete failure modes																		
Concrete material resistance factor	ϕ_c	-	0.65															
Resistance modification factor for shear, concrete failure modes, Condition B ³	R	-	1.0															
Load bearing length of anchor in shear	l_e	mm	38	38	51	64	38	51	64	83	70	83	102	83	95	121	102	146
Coefficient for prout strength	k_{cp}	-	1	1	1	2	1	1	2	2	2	2	2	2	2	2	2	2

¹See Figure 2.

²The KB-TZ2 is a ductile steel element as defined by CSA A23.3-14 D.2 or CSA A23.3-04 D.2, as applicable.

³For use with the load combinations of Division B, Part 4, Section 4.1.3 of the 2015 NBCC or 2010 NBCC, CSA A23.3-14 Annex C or CSA A23.3-04 Annex C, as applicable. Condition B applies where supplementary reinforcement in conformance with CSA A23.3-14 D.5.3(c) or CSA A23.3-04 D.5.4(c), as applicable, is not provided, or where pullout or prout strength governs. For cases where the presence of supplementary reinforcement can be verified, the strength reduction factors associated with Condition A may be used.

⁴1/4-inch and 1-inch diameter anchors are not permitted for core drilling installations.

TABLE 7—HILTI STAINLESS STEEL KB-TZ2 DESIGN INFORMATION FOR HAMMER AND CORE DRILLED INSTALLATIONS, SHEAR⁴

Design parameter	Symbol	Units	Nominal anchor diameter															
			1/4		3/8			1/2			5/8		3/4			1		
Anchor O.D.	d_a	mm	6.4		9.5			12.7			15.9		19.1			25.4		
Effective min. embedment ¹	h_{ef}	mm	38	38	51	64	51	64	83	70	83	102	83	95	121	102	146	
Shear, steel failure modes																		
Steel embed, material resistance factor for reinforcement	ϕ_s	-	0.85															
Resistance modification factor for shear, steel failure modes ²	R	-	0.75															
Steel strength in shear	V_s	kN	6.5	20.5	21.7	37.1	55.0	73.7	102.1	139.7								
Steel strength in shear, seismic	$V_{s,eq}$	kN	4.9	20.5	21.7	37.1	55.0	73.7	102.1	139.7								
Shear, concrete failure modes																		
Concrete material resistance factor	ϕ_c	-	0.65															
Resistance modification factor for shear, concrete failure modes, Condition B ³	R	-	1.0															
Load bearing length of anchor in shear	l_e	mm	38	38	51	64	51	64	83	70	83	102	83	95	121	102	146	
Coefficient for prout strength	k_{cp}	-	1	1	1	2	1	2	2	2	2	2	2	2	2	2	2	

¹See Figure 2.

²The KB-TZ2 is a ductile steel element as defined by CSA A23.3-14 D.2 or CSA A23.3-04 D.2, as applicable.

³For use with the load combinations of Division B, Part 4, Section 4.1.3 of the 2015 NBCC or 2010 NBCC, CSA A23.3-14 Annex C or CSA A23.3-04 Annex C, as applicable. Condition B applies where supplementary reinforcement in conformance with CSA A23.3-14 D.5.3(c) or CSA A23.3-04 D.5.4(c), as applicable, is not provided, or where pullout or prout strength governs. For cases where the presence of supplementary reinforcement can be verified, the strength reduction factors associated with Condition A may be used.

⁴1/4-inch and 1-inch diameter anchors are not permitted for core drilling installations.

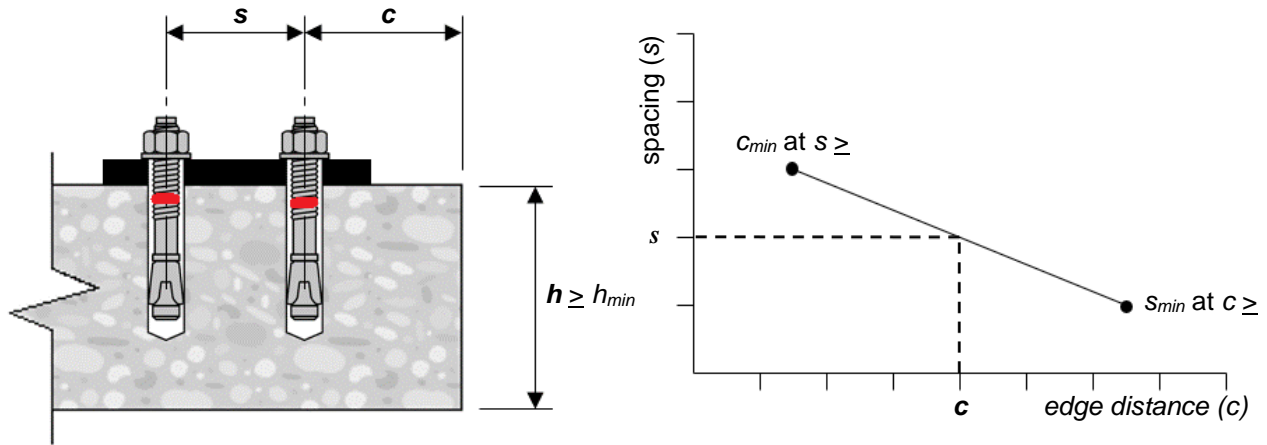

FIGURE 5—INTERPOLATION OF MINIMUM EDGE DISTANCE AND ANCHOR SPACING

Conditions of listing:

1. The listing report addresses only conformance with the standards and code sections noted above.
2. Approval of the product's use is the sole responsibility of the local code official.
3. The listing report applies only to the materials tested and as submitted for review by ICC-ES.
4. Anchor sizes, dimensions, minimum embedment depths and other installation parameters are as set forth in this report.
5. The anchors must be installed in accordance with the manufacturer's published instructions and this listing report. In case of conflict, this listing report governs.
6. Anchors must be limited to use in cracked and uncracked normal-weight concrete and lightweight concrete having a specified compressive strength, f'_c , of 20 MPa to 55 MPa.
7. The values of f'_c used for calculation purposes must not exceed 55 MPa.
8. Anchor spacing and edge distance as well as minimum member thickness must comply with Tables 3, 4 and 5, and Figure 5.
9. The use of fatigue or shock loading for these anchors under such conditions is beyond the scope of this listing report.
10. Anchors may be installed in regions of concrete where cracking has occurred or where analysis indicates cracking may occur ($f_t > f_r$), subject to the conditions of this report.
11. Anchors may be used to resist short-term loading due to wind or seismic forces in locations designed according to NBCC 2010 and NBCC 2015.
12. Where not otherwise prohibited in the code as referenced in CSA A23.3-14 or CSA A23.3-04, as applicable, KB-TZ2 anchors are permitted for use with fire-resistance-rated construction provided that at least one of the following conditions is fulfilled:
 - Anchors are used to resist wind or seismic forces only.
 - Anchors that support a fire-resistance-rated envelope or a fire-resistance-rated membrane are protected by approved fire-resistance-rated materials, or have been evaluated for resistance to fire exposure in accordance with recognized standards.
 - Anchors are used to support nonstructural elements.
13. Use of zinc-coated carbon steel anchors is limited to dry, interior locations.
14. Use of anchors made of stainless steel as specified in this report are permitted for exterior exposure and damp environments.
15. Use of anchors made of stainless steel as specified in this report are permitted for contact with preservative-treated and fire-retardant-treated wood.
16. Anchors are manufactured by Hilti AG under an approved quality-control program with inspections by ICC-ES.